

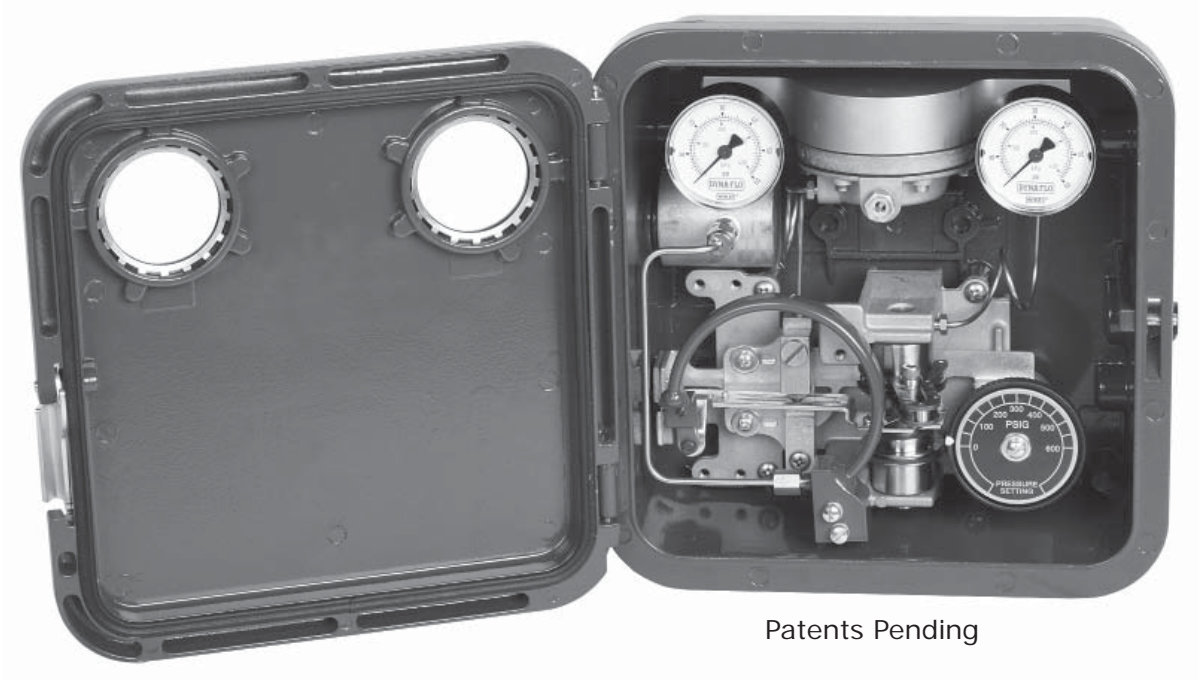

Instruction Manual October 2018 P-40LBM1018A

Model
4000LB Control Valve
Operation, Parts and Instruction Manuals



Dyna-Flo 4000LB

Operation, Parts and Instruction Manual

Table of Contents

Calibration	2
Adjustments	4
Maintenance	4
Changing Action	5
Relay Manifold	6
Output Signal	8
Start-Up & Tuning	9
Assembly Diagrams	11
Parts	14
Dimensions	18

Dyna-Flo Control Valve Services Ltd.
Edmonton, Alberta, CANADA
Website: www.dynaflo.com

Phone: 780 • 469 • 4000
Toll Free: 1 • 866 • 396 • 2356
Fax: 780 • 469 • 3149



Model **4000LB** Pressure Controller Operation, Parts and Instruction Manuals

!NOTICE!

These instructions are meant to be used with the Dyna-Flo 4000LB Series Technical Bulletin as they refer to Figures and Tables therein. If you do not have the Technical Bulletin, contact Dyna-Flo immediately, or visit www.dynaflo.com

Each controller is factory checked. Check the calibration for the specific application, before a controller is put into service.

Calibration Procedure Initial Set-up

The 4020LB Differential Gap Instructions are at the end of this section

- 1 It is recommended to calibrate the controller in the position in which it will be operated.
- 2 Determine supply pressure requirement by checking controller output signal range:
 - a) An output signal range of 6-30 PSI (41-207 KPA) would require 35 PSI (241 KPA) supply pressure.
 - b) An output signal range of 3-15 PSI (21-103 KPA) would require 20 PSI (140 KPA) supply pressure.
- 3 Connect a supply pressure line at the required setting, to the SUPPLY connection at the back of the case as shown in Figure 5.
- 4 Install 1/4" NPT pipe plug at the OUTPUT connection at the back of the case as shown in Figure 5. The controller output pressure change is measured by the output pressure gauge.
- 5 Locate a pressure supply (of compressed air or nitrogen) equivalent to the bourdon tube rating.
- 6 With the block valve closed, connect the pressure supply through a block valve and regulator to the CONTROL pressure block.

! NOTE !

There are 2 possible connections to the control pressure block:

- a) The CONTROL connection in the back of the case
- b) The connection at the left side of the case.

Plug the unused connection.

- 7 Verify that the calibration adjuster screws (Key 58) are at mid-point in the calibration adjuster (Figure 10, Key 41).
- 8 Inspect the following for leaks (using leak detection solution or soapy water).

4000LB / 4020LB Controller
Relay Manifold
All tubing and connections (relay & compensator)
Bellows, bellows frame and bellows screws

4010LB Controller
Relay Manifold
All tubing and connections (relay & compensator)
Bellows, bellows frame and bellows screws
Reset restrictor valve
Reset and compensator tubing
- 9 Set PRESSURE SETTING knob (Figure 10) at 0 (zero) setting.
- 10 Adjust the nozzle (Figure 10, Key 61), until the output pressure is between 8 and 10 PSI.

Calibration Procedure 4000LB and 4010LB Controller

! Note !

If the 4010LB is to be left at the maximum Reset setting, the 4010LB controller will perform as a 4000LB controller. It is recommended that the reset bellows tubing be removed and retubed as shown in Figure 2 for a 4000LB controller.



Model **4000LB** Control Valve Operation, Parts and Instruction Manuals

Calibration Procedure Initial Set-up (Continued)

Calibration Procedure 4000LB and 4010LB Controller (Continued)

- A** Adjust the cantilever set screw (Key 77) on the cantilever assembly to a setting of 1.5 as shown in Figure 3.
- B** For 4010LB set the reset knob (Key 28) on 0.01 minutes per repeat.
- C** Set the pressure dial (Key 45) to zero.
- D** With supply pressure connected adjust the nozzle until the output gauge reads 8-10 PSI.
- E** Apply input pressure to the bourdon tube equal to its rating.
- F** Rotate the pressure dial (Key 72) to the maximum setting which is equivalent to the bourdon tube rating.
- G** Output gauge reading should be between 8 and 10 PSI. If not, adjust the calibration adjuster (Key 41) as indicated below.

For direct-acting controller

- a) If output is below 8 to 10 PSI, move calibration adjuster to the left.*
- b) If output is above 8 to 10 PSI, move calibration adjuster to the right.*

For reverse-acting controller

- a) If output is below 8 to 10 PSI, move calibration adjuster to the right.*
- b) If output is above 8 to 10 PSI, move calibration adjuster to the left.*

- H** Repeat calibration adjuster movements until output gauge reads between 8 and 10 PSI on both zero and maximum value. (Maximum value is bourdon tube upper limit.)
- I** Isolate the controller from process, control, and supply pressure.
- J** Vent any trapped pressure from the controller.

4020LB Controller

- A** Temporarily set-up the 4020LB (differential gap) controller as a 4000LB (proportional band) controller, by changing the proportional band tubing connection to the bellows frame. The reversing block IS NOT inverted at this time.
- B** Calibrate as a 4000LB (proportional band) controller.
- C** After calibration, restore the bellows tubing (Key 16) to its original connection on the bellows frame.
- D** Due to physical differences in the bellows, there may be a slight shift in the output pressure. This will be adjusted out through nozzle adjustments described below.
- E** Set the cantilever set screw (Key 77) for the required differential gap (See **Adjustment** section for differential gap details).
- F** Set the process pressure:

Direct Acting Controller

1 Move the pressure setting to the upper switch point value at which the output pressure will go from zero, to full supply pressure, with rising process pressure.

2 Apply input pressure to the bourdon tube, as you observe the output gauge. When the upper switch point value is reached, while increasing input pressure, the controller output should switch from zero pressure, to full supply pressure.

3 Adjust the nozzle to correct any upper switch point error, and retest until the switch point and input pressure values agree.

Reverse Acting Controller

The controller output described above will be reversed.

- G** Check controller operation by running the input pressure from zero to above the upper switch point, and observing the switching points. Set a new differential gap, vary the input pressure, and then repeat with the calibration settings.



Model 4000LB Pressure Controller Operation, Parts and Instruction Manuals

Adjustments

Manual Set Point (4000LB/4010LB/4020LB)

Adjust the pressure setting by turning the pressure setting dial (Key 72) to the desired pressure. This represents the upper switch point for a direct acting 4020LB.

Proportional Band (4000LB and 4010LB)

Slide the cantilever set screw (Key 77) between setting 1-10 to adjust the sensitivity of the controller. 1 being the most sensitive, and 10 being the least sensitive. Factory setting is 1.5. A comparison is shown in Figure 3 showing the relationship between the standard 4000 Proportional Band Scale and the 4000LB Proportional Band Cantilever Assembly Scale.

Differential Gap (4020LB)

Adjust the cantilever set screw (Key 77) to set the width of the differential gap about the switch point. Use Table 1 as a guide. Calculate the Differential Gap as follows:

$$\frac{(\text{Upper Switch Point} - \text{Lower Switch Point}) \times 100}{\text{Boudon Tube Range}}$$

Proportional Band Setting	Differential Gap (% OF Element Range)
1	10
2	20
3	30
4	40
5	50
6	60
7	70
8	80
9	90
10	100

Table 1 - Differential Gap Setting Guide

Reset (4010LB only)

To adjust the reset action, rotate the reset knob (Figure 2) counter-clockwise to increase the speed. The minutes per repeat indicate the time required for the reset bellows pressure to equal the proportional bellows pressure.

Controller Maintenance

! WARNING !

The following maintenance procedures require taking the controller out of service. To avoid personnel injury, only qualified technicians should perform the following procedures. Always ensure the controller is fully released of pressure or process fluid before starting maintenance.

Regular Maintenance

- A** If the installation includes a supply regulator, periodically open the drain on the filter regulator to drain accumulated moisture.
- B** Push the cleaner wire on the relay orifice (Key 88, Figure 4) to release moisture or particulate.
- C** Inspect, and if necessary, clean the opening of the vent assembly (Key 29) or the remote vent pipe, if one is used.

Replacing Gauges

Refer to Figure 6.

- A** Quantity 2 gauges (Key 20) are used, one for output and one for supply pressure.
- B** Always ensure to check the range of the controller before ordering replacement gauges (0-30 PSI gauges WILL NOT work on a 6-30 PSI controller).
- C** Always use approved thread sealant on the threaded connections.

Replacing Bourdon Tube

Refer to Figures 10.

! WARNING !

Isolate the process sensing line prior to disconnecting the bourdon tube from the control tubing (Key 18). Be aware of potential hazards from disconnecting process connections.



Model **4000LB** Control Valve Operation, Parts and Instruction Manuals

Controller Maintenance (Continued)

Replacing Bourdon Tube (Continued)

- A** Disconnect the control tubing (Key 18) at the bourdon tube end.
- B** Remove the link bearing screw (Key 50) that connects the link (Key 42) to the beam (Key 39).
- C** Unscrew two screws (Key 54) and washers (Key 51), and remove the bourdon tube (Key 40).
- D** Remove the other link bearing screw (Key 50) that retains the link to the bourdon tube.
- E** Attach the link and bearing screw to the replacement bourdon tube.
- F** Attach the bourdon tube (Key 40) with two machine screws (Key 54) and washers (Key 51).
- G** Connect the link and bearing screw to the beam (Key 39).
- H** Check to make sure that the beam (Key 39) is reasonably parallel with the bottom of the case. For direct acting controllers in the ranges 30-200 PSI the bourdon tube may have to be rotated counter clockwise to allow for clearance for the cantilever. It may be difficult to maintain a parallel beam in these ranges which can complicate the calibration process but will not affect the operation of the controller.

! NOTE !

If a bourdon tube with a different range was installed, install a new dial having an adjustment range corresponding to the range of the bourdon tube. Remove the machine screws and washer (Key 54 & 51) and dial (Key 45).

! WARNING !

The following maintenance procedures require taking the controller out of service. To avoid personnel injury, only qualified technicians should perform the following procedures. Always ensure the controller is fully released of pressure or process fluid before starting maintenance.

- I** Check all tubing connections and the bourdon tube machine screws for leaks, tighten as necessary.
- J** Perform the calibration procedure.

Changing Band Cantilever Assembly

Refer to instructions under **Changing Action**.

Changing Reset Valve

- A** Disconnect the tubing and remove the reset restriction valve assembly (Figure 2) by removing a retaining screw (not shown) on the back of the controller.
- B** Install the desired replacement assembly.
- C** Use a proper thread sealant when reinstalling the tubing.
- D** Connect the tubing.
- E** Check all connections for leaks.
- F** Perform the calibration procedure.

Changing Action

Isolate the controller from process, control, and supply pressure. Vent any trapped pressure from the controller before proceeding.

Refer to Figure 2 or Cover Sticker (Key 14).

Direct to Reverse Action

Direct action

Increasing sensed pressure produces increasing output pressure



Model **4000LB** Pressure Controller Operation, Parts and Instruction Manuals

Changing Action (Continued)

Direct to Reverse Action (Continued)

Reverse action

Increasing sensed pressure produces decreasing output pressure.

- A** Refer to Figure 2, and locate the new tubing and reversing block positions for the action desired.
- B** Changing the action is accomplished by switching the position of 3 components.
- 1 the reversing block (Key 66).
 - 2 the bellows tubing (Key 16).
 - 3 the proportional band cantilever assembly
- C** In the controller, locate the two bellows, the reversing block and the proportional band cantilever assembly. See Figure 10.

For a 4000LB controller

Disconnect the bellows tubing (Key 16) from the bellows frame and reconnect it in the opposite hole. See Figure 2.

For a 4010LB (proportional-plus-reset) controller

Disconnect the bellows tubing (Key 16) and reset tubing (Key 27) from the bellows frame, and reconnect them in the opposite hole. See Figure 2.

For both Models of Controllers

- A** Remove the reversing block screw (Key 65, Figure 10) and reversing block assembly (Key 66).
- B** Inspect the o-rings (Key 62 and 63) located in the recessed area under the reversing block screw head and between the reversing block assembly and the calibration adjuster (Key 41, Figure 10). Replace these o-rings, if necessary.
- C** Position the reversing block assembly, with o-ring, on the calibration adjuster so that the nozzle is on the opposite side of the beam (Key 39) from which it was removed.

Properly position the reversing block assembly so that the alignment pin engages the hole in the calibration adjuster. Install the reversing block screw (Key 65) with o-ring (Key 62).

- D** Install the sealing screw with o-ring in the hole previously covered by the reversing block assembly.
- E** Install the relay tubing (Key 58) in the reversing block (Key 62).
- F** Using the provided 1/8 hex tool (Key 107), loosen the cantilever set screw (Key 77) and slide away from the bellows back to the 10 on the scale. Spread the cantilever assembly (Key 78) apart enough to allow the pins to come out of the holes in the bellows flanges. Remove Cantilever assembly and re-install on the opposite bellows flange. Make sure that the pins are properly installed in the holes. See Figure 9. Follow instructions under **Replace Bourdon Tube**, when using 30-200 PSI tube.
- H** Check all the connections for leaks with leak detector solution.
- G** Perform the calibration procedure.

Relay Manifold

Replacement

Refer to Figure 4.

- A** Always shut down the supply, control and process pressure line to the controller.
- B** Disconnect the relay tubing (Key 26) from the relay manifold (Key 86).
- C** Remove the relay manifold (Key 86) from the case by unscrewing the 2 retaining screws (Key 86A) on the back of the case.
- D** Remove the gauges and bellows tubing from the manifold. Install the gauges and bellows tubing into the new replacement manifold.
- E** Replace the relay manifold o-rings (Key 25). Place the o-rings on the inlet and outlet fittings on the relay manifold. With the manifold in place, insert and fasten the 2 screws (Key 86A) from the backside of the case.



Model 4000LB Control Valve Operation, Parts and Instruction Manuals

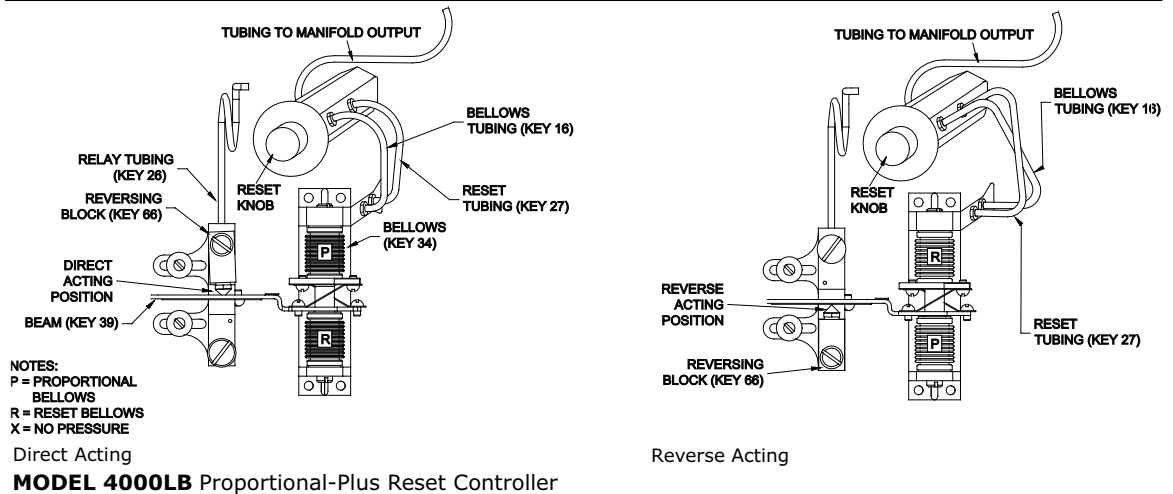
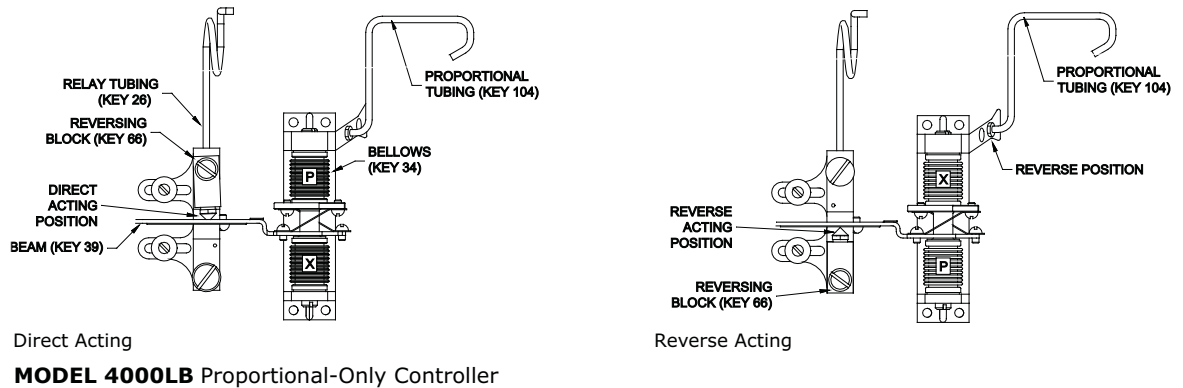

Figure 2 Tubing Connections

Relay Manifold (Continued)

Replacement (Continued)

- F Connect the tubing, and check all connections for leaks.
- G Perform calibration procedure.

Relay Reconditioning

Refer to Figure 4.

Disassembly

- A Complete steps A through D of relay manifold replacement.

- B Unscrew the orifice assembly (Key 88). Remove the o-rings (Key 84) from the orifice assembly.
- C Place the relay manifold on the work surface with the casing screws facing up. Remove the casing screws (Key 83), in a criss-cross pattern.
- D Remove and separate the lower casing (Key 81) bottom diaphragm (Key 80), spacer ring (Key 84), diaphragm assembly (Key 89), relay spring (Key 87), and valve plug spring (Key 93) from the relay manifold (Key 86).



Model **4000LB** Pressure Controller Operation, Parts and Instruction Manuals

Relay Manifold (Continued)

Relay Reconditioning (Continued)

Disassembly (Continued)

- F** To install a replacement seat ring (Key 90) in the relay manifold, remove the 3 screws (Key 82) and washers (Key 85) retaining the seat ring. Remove the seat ring (Key 90), and o-ring (Key 79) from the seat pocket in the relay manifold.
- G** Inspect diaphragms and gaskets, and replace them if necessary.
- H** Replace the spring and valve plug if they show signs of corrosion.
- I** The lower diaphragm is part of the diaphragm assembly and must be replaced as an assembly.
- J** Clean all parts thoroughly before re-assembling.
- F** Install the casing screws (Key 83), but do not tighten them. Once they are all in, tighten in a criss-cross pattern.
- G** Install the o-rings (Key 84) on the orifice assembly (Key 88), and install the orifice assembly into the diaphragm casing.
- H** Replace the relay manifold o-rings (Key 25). Place the o-rings on the inlet & outlet fittings on the relay manifold. With the manifold in place, insert and fasten the 2 screws (Key 86A) from the backside of the case.
- I** Install the NPT (Key 30), gauges (Key 20), and relay tubing (Key 26). Check all connections for leaks.
- J** Perform the calibration procedure.

Re-assembly

- A** With the opening in the relay manifold facing up, place the valve plug spring in the bottom of the manifold. Carefully place the valve plug on top of the spring, such that the plug is pointing up. Install the small o-ring in the relay seat.
- B** Install the seat o-ring (Key 79) in the pocket of the relay manifold. Carefully place the seat ring on top of the o-ring, ensuring the plug is sticking through the relay seat o-ring.
- C** With the seat ring in place, install the 3 screws (Key 82) and washers (Key 85) that retain the seat ring.
- D** Place on the relay manifold (Key 86), in order, the relay spring (Key 87), diaphragm assembly (Key 80), spacer ring (Key 89) and the top diaphragm (Key 91). Ensure all the flow passage holes are lined up.
- E** Once the assembly of all these components is complete, the diaphragm casing can then be

Changing Output Signal Range

Changing the output signal range simply requires the replacement of the Cantilever Assembly. There are two different Cantilever Assemblies. One for 3-15 Psig range and another for 6-30 Psig range. See parts list for details. Follow Cantilever removal instructions under **Changing Action, Page 6**.



Model **4000LB** Control Valve Operation, Parts and Instruction Manuals

Start-Up & Tuning Guidelines

4000LB

- 1 Check that controller is calibrated.
- 2 Check that supply regulator set point matches the controller output range.
- 3 Set the pressure setting knob at the required pressure.
- 4 Based on your process (fast, or slow) set the proportional band:

a) for a fast (liquid) system, use a setting of 10 (100 percent)

b) For slow (gas) system uses a calculated proportional band setting, from the expression:

$$\frac{20 \times \text{Allowable Error}}{\text{Output Pressure Range}} \\ (\times 10 \text{ for percent value})$$

Example:

- 3 Psig Allowable Error
- 30 Psig Output Range
 $20 \times 3 / 30 = \text{setting of } 2 \text{ (20\% PB)}$

- 5 Check the proportional action by either making a small set point change, or bumping the flapper lightly, and watching for the output to cycle. Lower the proportional band setting if the system does not cycle, and check again. Repeat this process until the controller output does cycle, and then double proportional band setting for a reasonable starting point.
- 6 Minimize proportional band effect on set point by turning the nozzle (Key 61) until the process pressure matches the controller pressure setting.
- 7 Check the proportional band setting for stable operation by making a change in the process and watching for cycling.

4010LB

- 1 Check that controller is calibrated.
- 2 Check that supply regulator set point matches the controller output range.
- 3 Set the pressure setting knob at the required pressure.
- 4 Based on your process (fast, or slow) set the reset:

a) for a fast (liquid) system use 0.05 minutes per repeat

b) for a slow (gas) system use 0.5 minutes per repeat

- 5 Based on your process (fast, or slow) set the proportional band:

a) for a fast (liquid) system, use a setting of 10 (100 percent)

b) for slow (gas) system uses a calculated proportional band setting, from the expression:

$$\frac{20 \times \text{Allowable Error}}{\text{Output Pressure Range}} \\ (\times 10 \text{ for percent value})$$

Example:



- 3 Psig Allowable Error
- 30 Psig Output Range
 $20 \times 3 / 30 = \text{setting of } 2 \text{ (20\% PB)}$

- 6 Check the proportional action by either making a small set point change, or bumping the flapper lightly, and watching for the output to cycle. Lower the proportional band setting if the system does not cycle, and check again. Repeat this process until the controller output does cycle, and then double proportional band setting for a reasonable starting point.
- 7 Check the reset action by either making a small set point change, or bumping the flapper lightly, and watching for the output to cycle. Increase the reset setting if the system does not cycle, and check again. Repeat this process until the controller output does cycle, and then triple that reset setting for a reasonable starting point.
- 8 Check the reset setting for stable operation by making a change in the process and watching for cycling.

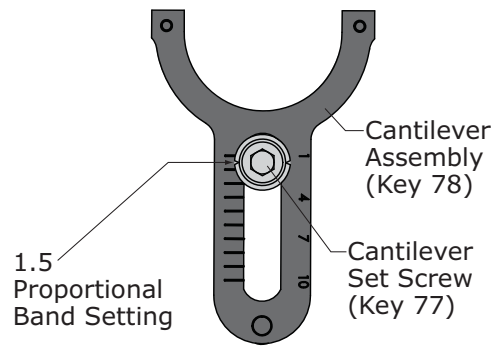

Model
4000LB Pressure Controller
 Operation, Parts and Instruction Manuals

Figure 3 Proportional Band Design Setting Comparison

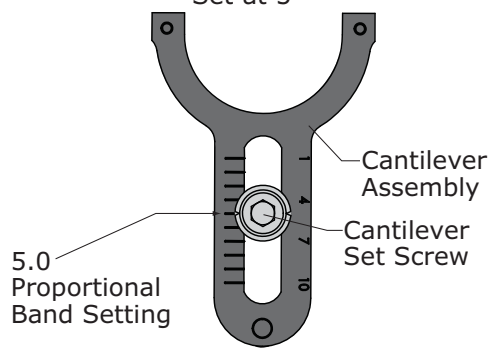
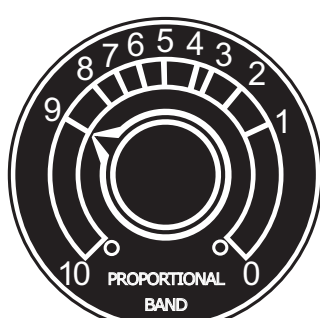
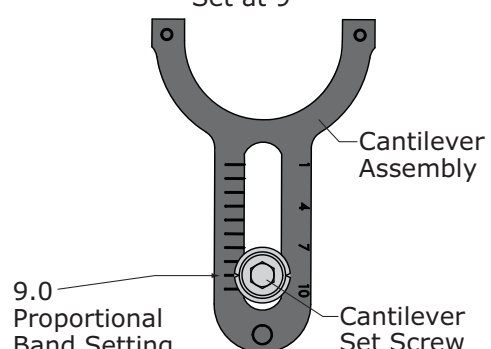
<p>Model 4000 Proportional Band Adjustment Knob Set at 1.5</p> 	<p>Model 4000LB Proportional Band Adjustment Cantilever Set Screw Set at 1.5</p>  <p>1.5 Proportional Band Setting</p> <p>Cantilever Assembly (Key 78)</p> <p>Cantilever Set Screw (Key 77)</p>
<p>Model 4000 Proportional Band Adjustment Knob Set at 5</p> 	<p>Model 4000LB Proportional Band Adjustment Cantilever Set Screw Set at 5</p>  <p>5.0 Proportional Band Setting</p> <p>Cantilever Assembly</p> <p>Cantilever Set Screw</p>
<p>Model 4000 Proportional Band Adjustment Knob Set at 9</p> 	<p>Model 4000LB Proportional Band Adjustment Cantilever Set Screw Set at 9</p>  <p>9.0 Proportional Band Setting</p> <p>Cantilever Assembly</p> <p>Cantilever Set Screw</p>



Model
4000LB Control Valve
 Operation, Parts and Instruction Manuals

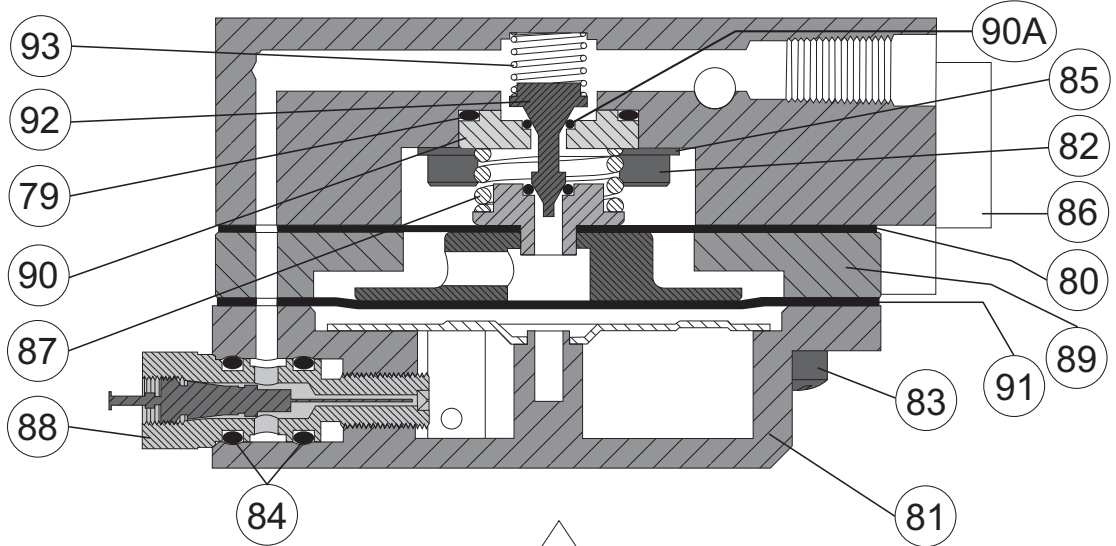

Figure 4 Relay Manifold Cross Section

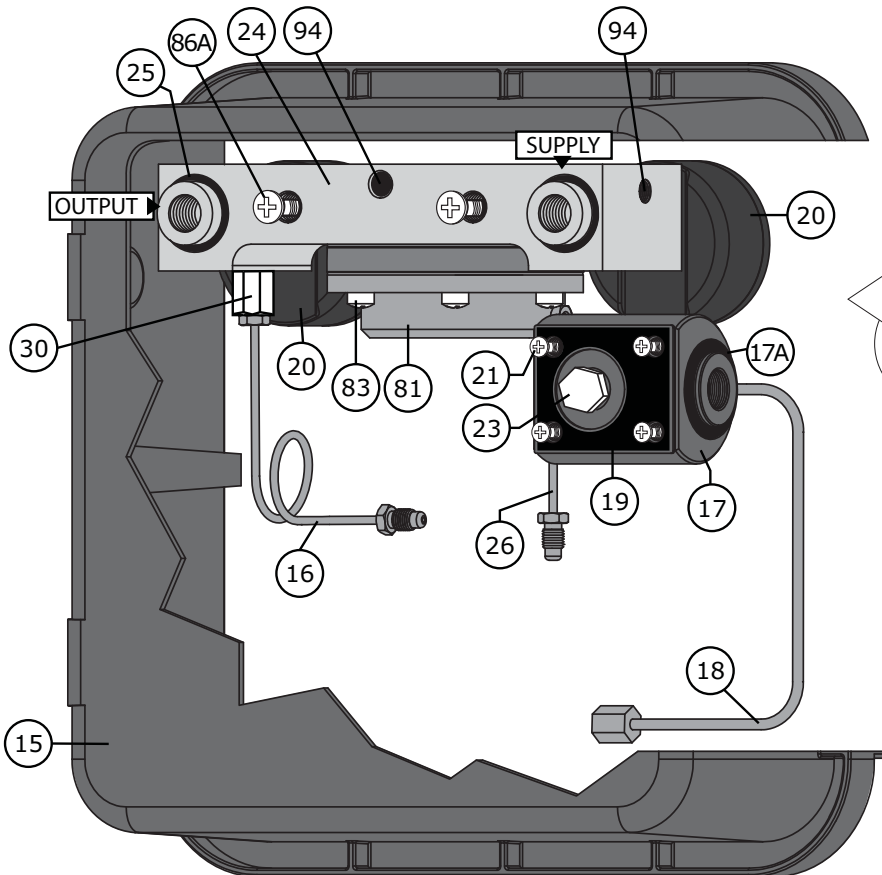

Figure 5
 4000LB Case Assembly
 Back View



Model
4000LB Pressure Controller
 Operation, Parts and Instruction Manuals

Figure 6
 4000LB Case Assembly
 Front View

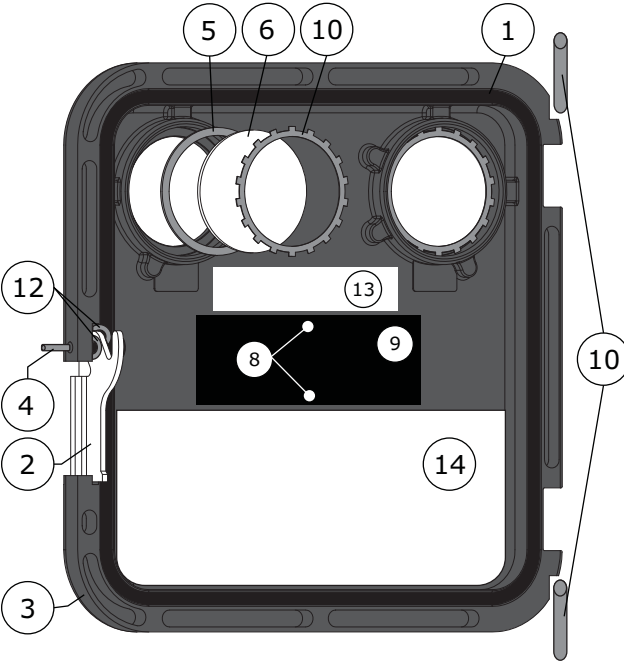
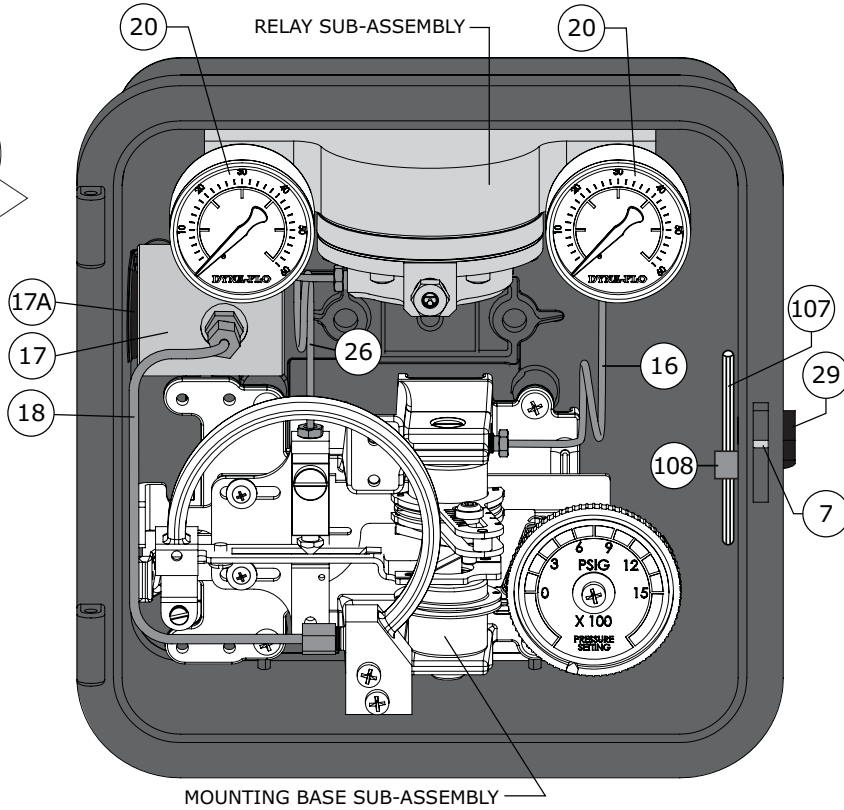

Figure 7
 4000LB Case Cover
 Assembly



Model
4000LB Control Valve
 Operation, Parts and Instruction Manuals

Figure 8 Bellows Sub-Assembly

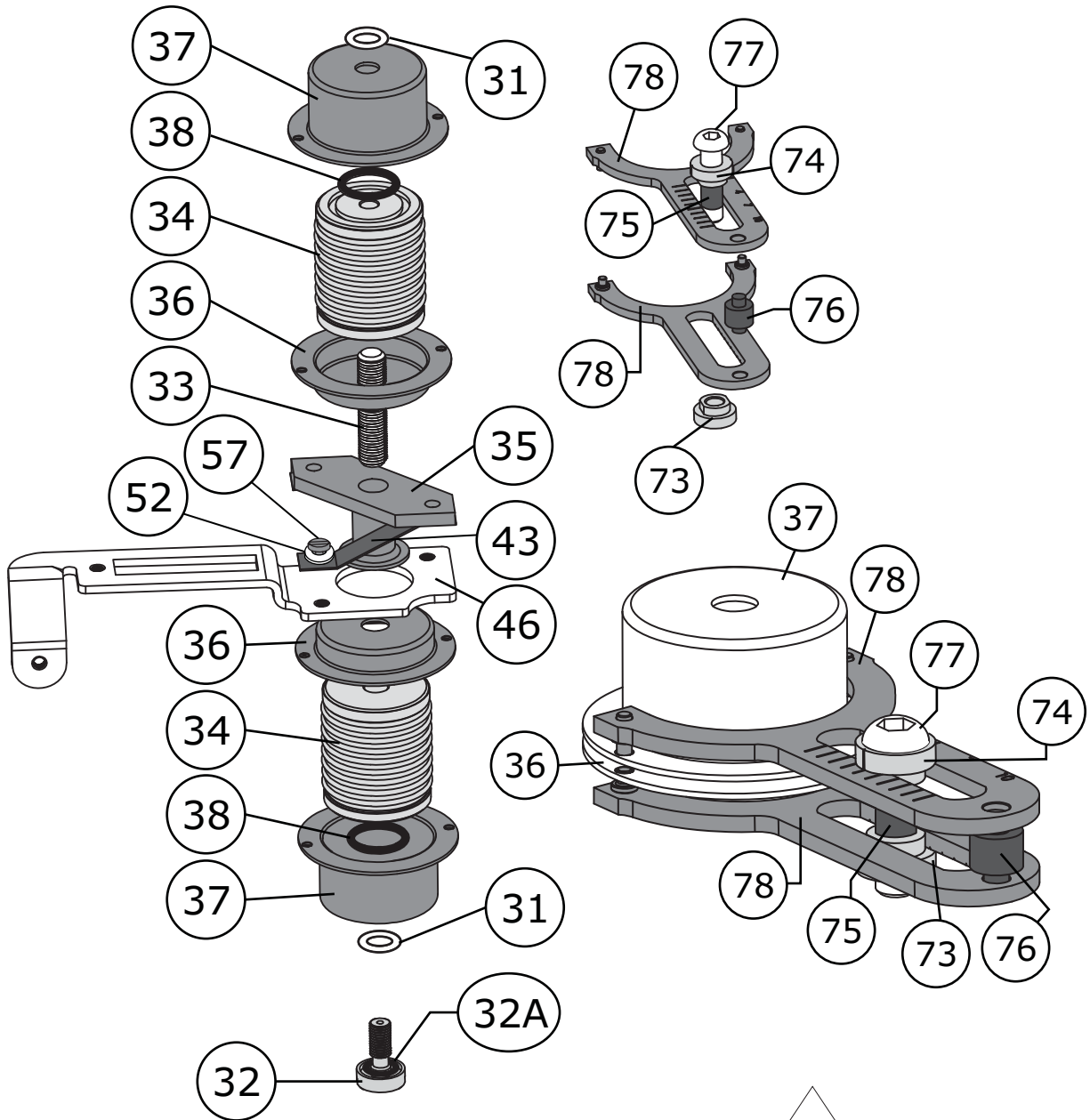

Figure 9 Proportional Band Cantilever Assembly



Model
4000LB Pressure Controller
 Operation, Parts and Instruction Manuals

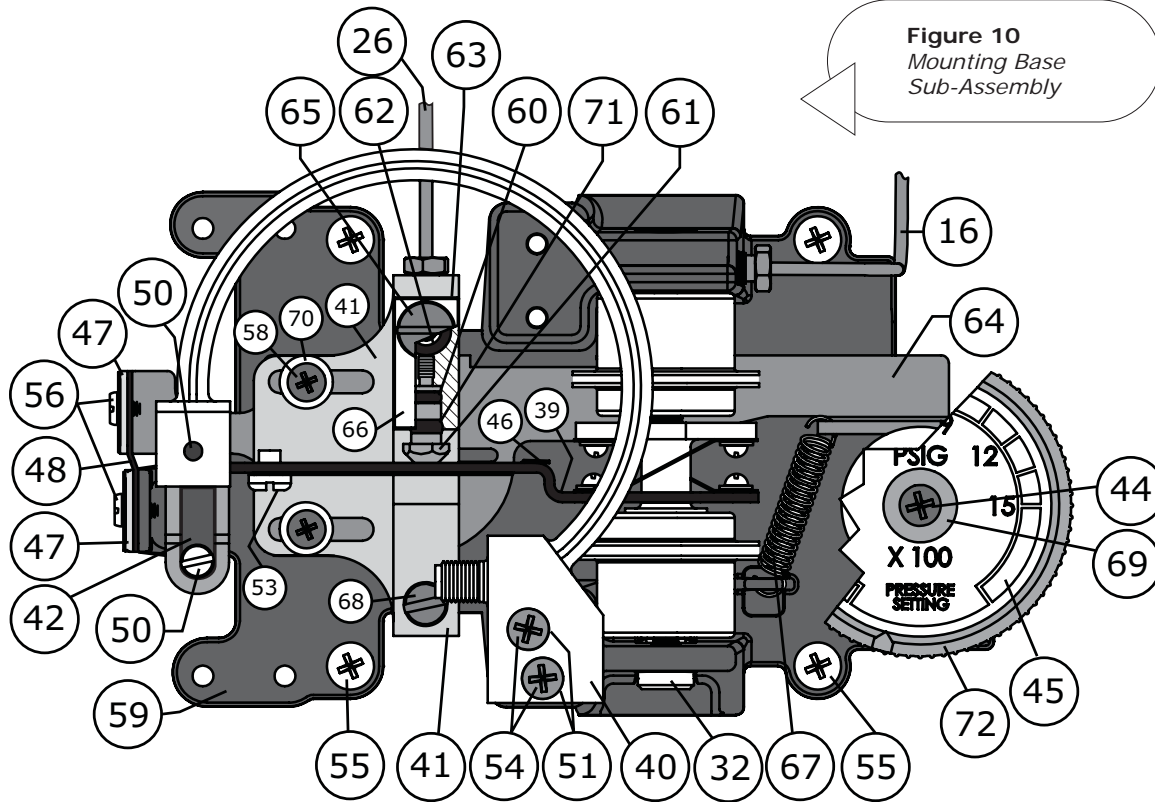

Figure 10
 Mounting Base
 Sub-Assembly

Parts Ordering

Whenever corresponding with Dyna-Flo about a 4000LB series pressure controller, refer to the nameplate (Key 9, Figure 7) for the serial number of the unit. Please order by the complete part number (as given in the following parts list) of each part required.

Repair Kits

Controller Repair Kit

R4000LBXL1D

Kit Contains Keys: 1, 5, 17A, 19, 25, 31, 32A, 38, 42, 46, 50, 53, 60, 61, 62, 63, 65, 68, 84

Relay Repair Kit

RRELAYLBXL1D

Kit Contains Keys: 79, 80, 84, 90, 90A, 91, 92



Model
4000LB Control Valve
 Operation, Parts and Instruction Manuals

Parts

Case Cover (See Figure 7)

Key	Description	Part Number
1	Cover Gasket , Nitrile	1J40750643D
2	Cover Latch , Steel Plated	1H28862898D
3	Cover , Aluminum	PC00000011D
4	Latch Pin , Steel Plated	PC00000003D
5	Gasket , Gauge Glass, Neoprene, Qty: 2	0T01910408D
6	Gauge Glass , Qty: 2	DF5000X044D
7	Latch Roll Pin , Steel Plated	PC00000003D
8	Nameplate Screw , Steel Plated, Qty: 2	1C94192898D
9	Nameplate , SST	PC00000013D
10	Retaining Ring , Gauge Glass, SST, Qty: 2	PC00000006D
11	Roll Pin , Cover Hinge, SST, Qty: 2	1H28882899D
12	Spring Washer , Cover Latch, Steel Plated, Qty: 2	PC00000004D
13	Calibration Sticker , Vinyl	INSTCALSTICK
14	Cover Sticker , Vinyl	PC0000X124D

Case (See Figure 5 & 6)

Key	Description	Part Number
15	Case , Aluminum	PC00000044D
16	Bellows Tubing , SST 4000LB 4010LB -Bellows Tubing -Reset Tubing, Qty: 2	PC0000X118D 1H6868000AD
17	Control Pressure Block , Steel Plated (old style) (new style)	PC00000024D PC00000024X
17A	O-Ring , Control Pressure Block, Neoprene (old style) (new style)	1C37620699D DF20781X01D
18	Control Tubing Assembly , SST	PC00000023D
19	Gasket , Pressure Block, Neoprene	1C32860301D
20	Gauge , Qty: 2 0-30 Psig 0-60 Psig	PC000000037D PC000000038D

Case (Continued)

Key	Description	Part Number
21	Machine Screw , Pressure Block, Steel Plated, Qty: 4	PC00000026D
22	Mounting Screw , Reset Valve, Steel Plated	1H52702898D
23	Pipe Plug , Pressure Block, Steel	1A76752466D
24	Relay Manifold Assembly	PC0000X119D
25	O-Ring , Relay Manifold, Nitril, Qty: 2	PC00000071D
26	Relay Tubing Assembly , SST	1H6861000AD
27	Reset Tubing Assembly , 4010LB, SST	1H6866000AD
28	Reset Valve Assembly , 4010LB	10A9129X0AD
29	Vent Assembly , Plastic/SST	Y602-12D
30	NPT Fitting , Bellows Tubing to Manifold, SST	PC0000X113D

Bellows Sub-Assembly (See Figure 8)

Key	Description	Part Number
31	Bellows Gasket , Neoprene, Qty: 2	1D39700301D
32	Bellows Screw , SST, Qty: 2	22B8036X02D
32A	O-Ring , Screw, Nitrile, Qty: 2	1D68750699D
33	Bellows Stud , SST	1H2658X001D
34	Bellows , SST, Qty: 2	PC0000X117D
35	Cross Spring Spacer , Aluminum	1H26594401D
36	Bellows Flange , Shallow Cup, SST, Qty: 2	PC0000X110D
37	Bellows Flange , Deep Cup, SST, Qty: 2	PC0000X114D
38	O-Ring , Bellows Flange, Nitrile, Qty: 2	PC0000X126D

Mounting Base Sub-Assembly

(See Figure 10)

Key	Description	Part Number
39	Beam , SST	1H26682507D
40	Bourdon Tube , SST 0-30 Psig 0-60 Psig	10B2892X01D 10B2892X02D



Model
4000LB Pressure Controller
 Operation, Parts and Instruction Manuals

Parts (Continued)

Mounting Base Sub-Assembly
 (Continued) (See Figure 10)

Key	Description	Part Number
40	Bourdon Tube, Continued	
	0-100 Psig	10B2892X03D
	0-200 Psig	10B2892X04D
	0-300 Psig	10B2892X05D
	0-600 Psig	10B2892X06D
	0-1000 Psig	10B2892X07D
	0-1500 Psig	10B2892X08D
	0-3000 Psig	10B2892X09D
	0-5000 Psig	10B2892X10D
	0-8000 Psig	10B2892X11D
	0-10,000 Psig	10B2892X12D
41	Calibration Adjuster, Steel Plated	2H26624401D
42	Connecting Link, SST	1L37964101D
43	Cross Spring, SST, Qty: 2	1H26603703D
44	Dial Screw, Steel Plated	1J84152898D
45	Dial, SST	
	0-30 Psig	16A7662X01D
	0-60 Psig	16A7662X02D
	0-100 Psig	16A7662X03D
	0-200 Psig	16A7662X04D
	0-300 Psig	16A7662X05D
	0-600 Psig	16A7662X06D
	0-1000 Psig	16A7662X07D
	0-1500 Psig	16A7662X08D
	0-3000 Psig	16A7662X09D
	0-5000 Psig	16A7662X10D
	0-8000 Psig	16A7662X11D
	0-10,000 Psig	16A7662X12D
46	Flapper, SST	1H26694113D
47	Flexure Strip Washer, Steel Plated, Qty: 2	16A7671X01D
48	Flexure Strip, SST	1C89783601D
49	Knob Spring, Steel Plated	1C22152702D
50	Link Bearing Screw, SST, Qty: 2	PC00000041D

Mounting Base Sub-Assembly
 (Continued)

Key	Description	Part Number
51	Lockwasher, Bourdon Tube, Steel Plated, Qty: 2	1H26722898D
52	Lockwasher, Steel Plated, Qty: 2	1H26712898D
53	Machine Screw, Flapper, Steel Plated	1B27512898D
54	Machine Screw, Bourdon Tube, Steel Plated, Qty: 2	1H26772898D
55	Machine Screw, Mounting Base, Steel Plated, Qty: 4	PC00000040D
56	Machine Screw, Flexure Strip, Steel Plated, Qty: 4	14B4995X01D
57	Machine Screw, Cross Springs, Steel Plated, Qty: 4	1V74352898D
58	Machine Screw, Calibration Adjuster, Steel Plated, Qty: 2	1A5733X001D
59	Mounting Base, Aluminum	26A7668X01D
60	O-Ring, Nozzle - Top, Nitrile	1E22260699D
61	Nozzle, Reversing Block, SST	PC00000080A
62	O-Ring, Under Reversing Block Screw, Nitrile	1D68750699D
63	O-Ring, Under Reversing Block, Nitrile	1D68750699D
64	Pressure Arm, Steel Plated	36A7669X01D
65	Reversing Block Screw, SST	24A5720X01D
66	Reversing Block, Steel Plated	26A0975X01D
67	Rotary Spring, SST	1J42343702D
68	Sealing Screw, SST	14A5721X01D
69	Washer, Dial, Steel	1R98202507D
70	Washer, Calibration Adjuster, Steel Plated, Qty: 2	1E87302899D
71	O-Ring, Nozzle - Bottom, Nitrile	PC00000060D
72	Dial Holder, Plastic	36A7670X01D



Model
4000LB Control Valve
 Operation, Parts and Instruction Manuals

Parts (Continued)

Cantilever Sub-Assembly (See Figure 9)

3-15 Psig Assembly	PC0000X123D
6-30 Psig Assembly	PC0000X109D

Key Description

73	Bottom Locknut , Cantilever Adjustment Screw, SST
74	Top Locknut , Cantilever Adjustment Screw, SST
75	Center Sleeve , Cantilever Adjustment Screw, SST
76	Rear Sleeve , Cantilever Adjustment Screw, SST
77	Cantilever Adjustment Screw , SST
78	Cantilever Assembly , SST, Qty: 2

Relay Sub-Assembly (See Figure 4)

Key Description Part Number

79	O-Ring , Relay Seat Ring, Nitrile	PC00000069D
80	Diaphragm Assembly ,	18A2451X44D
81	Diaphragm Casing Assembly , Aluminum/Steel	12B0460X01D
82	Machine Screw , SST, Qty: 3	PC00000055D
83	Machine Screw , Steel, Qty: 6	1C89692898D
84	O-Ring , Nitrile, Qty: 2	1D68750699D
85	Washer , Relay Seat, Steel Plated, Qty: 3	PC00000053D
86	Relay Manifold , Aluminum	PC00000049D
86A	Socket Cap Screw , Steel, Manifold/Case, Qty: 2	PC00000051D
87	Relay Spring , Steel Plated	1C89612701D
88	Relay Orifice Assembly	12B0468X01D
89	Spacer Ring , Aluminum	38A3778X01D
90	Seat Ring , SST	PC00000075D
90A	O-Ring , Plug Seat, Nitrile	PC00000060D
91	Top Diaphragm	1L55560204D
92	Valve Plug , SST	OY0617X002D
93	Valve Spring , SST	OX08363702D
94	Set Screw , SST, Qty: 3	PC00000048D

Case Mounting Parts (See Figure 11 & 12)

Key Description Part Number

95	Cap Screw , Wall or Panel Mount, Steel Plated, Qty: 4	1B84802405D
96	Cap Screw , Steel Plated	
	5/16 UNC x 1 Inch	1A35262405D
	5/16 UNC x 3/4 Inch	1A38162405D
97	Cap Screw , Steel Plated, Qty: 4	1C33332898D
98	Hex Nut , Steel Plated, Qty: 4	1C33282898D
99	Lockwasher , Steel Plated, Qty: 2	1C22572898D
100	Machine Screw , Steel Plated, Qty: 2	1C63922898D
101	Mounting Bracket , Actuator Casing, Steel Plated	1F40122507D
102	Mounting Bracket , Actuator Yoke, Steel Plated	1C22182502D
103	Mounting Bracket , Panel or Wall, Steel Plated, Qty: 2	1H2892000AD
104	Mounting Bracket , Pipestand, Steel Plated	3N97572509D
105	Mounting Spacer , Steel Plated	1F90672409D
106	Pipe Mounting Clamp , Steel, Qty: 2	1P42702898D

Tools (See Figure 6)

Key Description Part Number

107	Hex Wrench , Steel, Case	PC0000X129D
108	Hex Clip , Plastic, Case	PC0000X128D



Model
4000LB Pressure Controller
 Operation, Parts and Instruction Manuals

Figure 11 Model 4000LB Mounting Details,
 Pipestand, Surface Panel

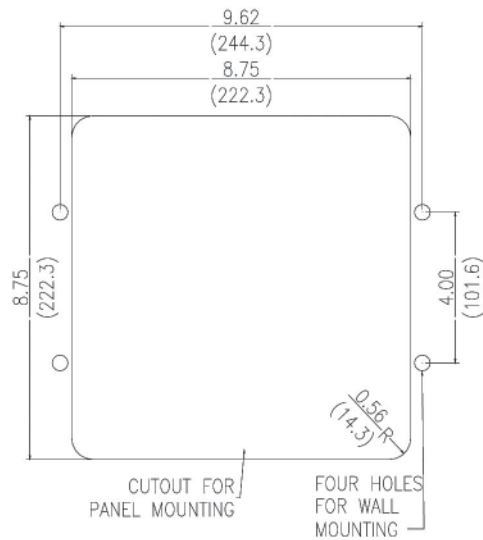
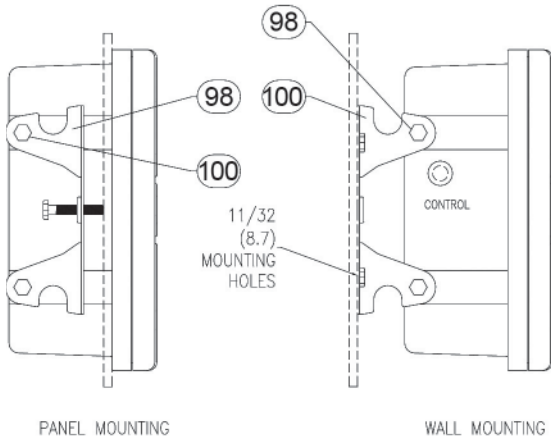
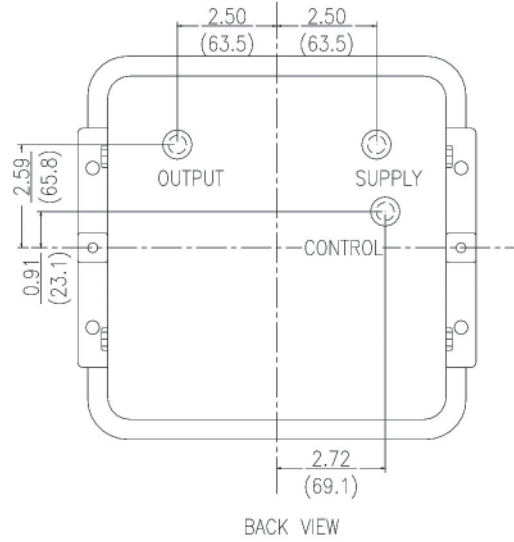
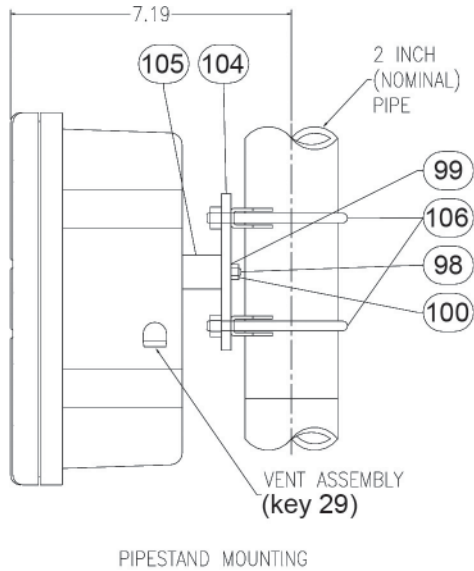

INCH
(mm)



Model
4000LB Control Valve
Operation, Parts and Instruction Manuals

NOTE
When using yoke style
mounting, DON'T PUNCH
HOLES in back of case.
Use drill.

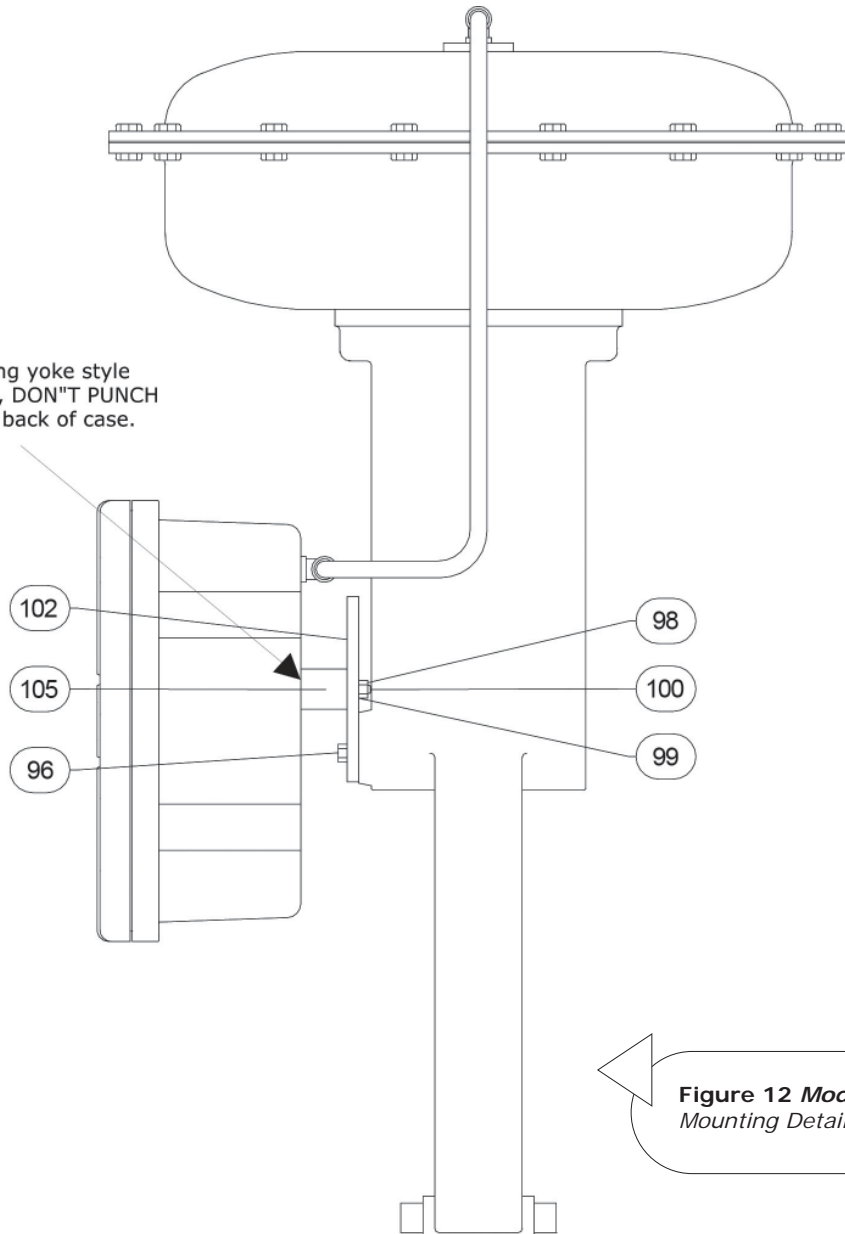

Figure 12 Model 4000LB
Mounting Details, Actuator Yoke

Our Commitment of Quality

Dyna-Flo is committed to continuous improvement. All efforts have been taken to maximize the accuracy of this information. Without notification, product specifications and designs may be modified at any time. The issue of this document is for information only, and does not imply suitability, a warranty, or guarantee for a specific service.



Model
4000LB Pressure Controller
 Operation, Parts and Instruction Manuals

Dyna-Flo 4000LB Pressure Controller | Model Numbering System

Ordering Guide

Sample Part Number

4000LB-010-D-10

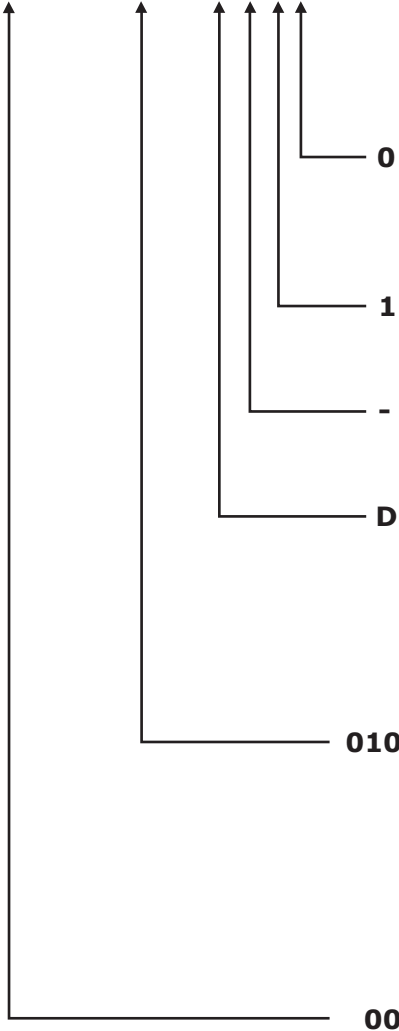

Code	Description
Options	
0	None
1	NACE Process Only
2	Sour Instrument Only
3	NACE Process and Sour Instrument
X	Special
Controller Output	
1	3 to 15 psig (21 to 103 kPag) / 0 to 20 psig (0 to 138 kPag)
2	6 to 30 psig (41 to 207 kPag) / 0 to 30 psig (0 to 207 kPag)
Options	
-	None (standard)
S	Bourdon Tube Stop
Controller Action	
D	Direct
R	Reverse
Input Signal Range	
003	0 to 30 Psig (207 kPag)
006	0 to 60 Psig (414 kPag)
010	0 to 100 Psig (689 kPag)
020	0 to 200 Psig (1379 kPag)
030	0 to 300 Psig (2068 kPag)
060	0 to 600 Psig (4137 kPag)
100	0 to 1000 Psig (6895 kPag)
150	0 to 1500 Psig (10342 kPag)
300	0 to 3000 Psig (20684 kPag)
500	0 to 5000 Psig (34474 kPag)
Note: consult factory for higher input signal ranges	
Controller Mode	
00	Proportional
10	Proportional + Reset
20	Bellows Sensing
30	Differential Gap

NOTE: order mounting kits separately