

Model 4000 Pressure Controller

Technical Sales Bulletin

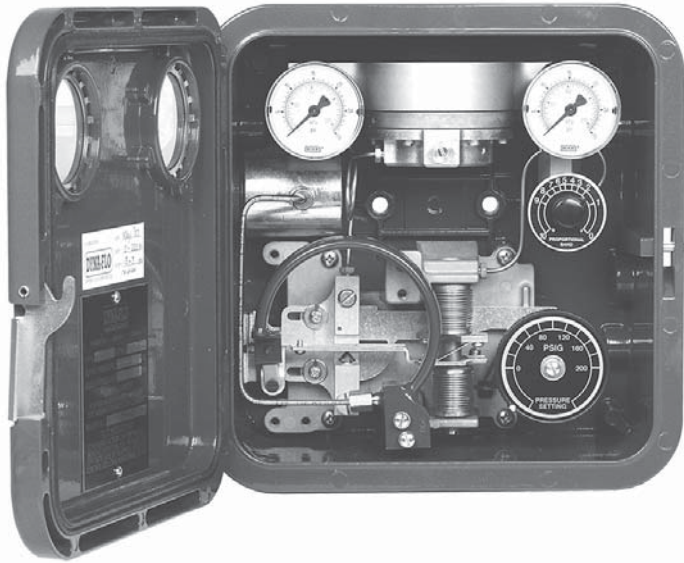

Figure 1 Model 4000 Pressure Controller

The Dyna-Flo 4000 Series pneumatic pressure controllers are used in all kinds of demanding applications, including oil and gas production and chemical process industries.

Pressure controllers are the “brains” of a self contained, local pneumatic control loop.

The pressure controller (Figure 1) detects the process pressure using a Bourdon tube sensing element. The process pressure is then compared to an operator-adjusted set point, which in turn modulates the controller output. The controller’s pneumatic output is connected to a final control device, typically a control valve, that changes the process pressure.

The Dyna-Flo 4000 Series pneumatic pressure controllers are manufactured to a high level of quality specifications to ensure superior performance and customer satisfaction.

FEATURES

Multiple Configurations

The 4000 series pressure controller can be configured into either proportional only or proportional plus reset mode with a minimum of parts.

Rugged Design

Die cast aluminum case and cover can withstand impacts that would fracture plastic cases.

Corrosion Resistant Construction

The standard powder coated casting, stainless steel external fasteners, and standard stainless tubing ensure long and reliable operation.

Flexible Action

Control action is field reversible between direct acting and reverse acting without additional parts.

Instrument Gas Tight Case

A standard feature for controlled venting when using natural gas as power gas.

Wide Range of Pressure Elements

Bourdon tube ranges from a minimum of 30 Psig (207 kPag) to a maximum 5,000 Psig (34,474 kPag). Contact factory for bellow ranges.

Bourdon Tube Materials

Bourdon tube materials are S31600 for standard application and N05500 for NACE process applications.

Sour Instrument Gas Capability

Stainless steel gauges, relay, tubing and bellows are available for applications using sour instrument gases.



Model 4000 Pressure Controller

Technical Sales Bulletin

SPECIFICATIONS

Models

- Model 4000 - Proportional Only Controller
- Model 4010 - Proportional-Plus-Reset Controller
- Model 4020 - Bellows Sensing
- Model 4030 - Differential Gap Controller

Performance

- Repeatability: 0.5% of sensing element range
- Deadband: 0.1% of output span
- Differential Gap: 15-100% of sensing element range

Reset Adjustment

For Proportional-plus-reset controller: Adjust from 0.01 to 74 minutes per repeat (100 to 0.01 repeats per minute).

Approximate Weight

12 pounds (5.5 kg)

Ambient Operating Temperature Limits

-40° to 160° F (-40° to 71° C).

Input Signal

Limits: See Table 1.

Output Signal Range

- 3-15 Psig (21 to 103 kPag)
- 6-30 Psig (41 to 207 kPag)

Pressure Connections

All pressure connections on 4000 Series controllers are 1/4 inch NPT female. Use 1/4-inch (6mm) or 3/8-inch (10mm) pipe or tubing for supply, and output. Vent lines should increase 1 pipe size every 10 feet, or, be kept as short as possible.

Steady-State Air Consumption

See Table 2.

Supply Pressure Requirements

See Table 2.

Controller Action

Control action is field reversible between direct acting (increasing sensed pressure produces increasing output signal), and reverse acting (increasing sensed pressure produces decreasing output signal) without additional parts.

Dimensions

See Figure 5.

Mounting Information

Mounting Kits are available for actuator yoke, actuator casing, panel mount, wall mount and 2" pipe stand mounting. See Figure 5 and 6.

For more information and other options contact your Dyna-Flo sales office.

Bourdon Tube Pressure and Materials				
Pressure Ranges		Maximum Allowable Static Pressure Limit		Materials
Psig	kPag	Psig	kPag	
0 - 30	0 - 207	30	207	S31600
0 - 60	0 - 414	60	414	S31600
0 - 100	0 - 689	100	689	S31600
0 - 200	0 - 1,379	200	1,379	S31600
0 - 300	0 - 2,068	300	2,068	S31600
0 - 600	0 - 4,137	600	4,137	S31600*
0 - 1,000	0 - 6,895	1,000	6,895	S31600*
0 - 1,500	0 - 10,342	1,500	10,342	S31600*
0 - 3,000	0 - 20,684	3,000	20,684	S31600
0 - 5,000	0 - 34,474	5,000	34,474	S31600

* - Available in N05500 (other materials and ranges special order).

Model 4000 Pressure Controller

Technical Sales Bulletin



Table 2

Supply Pressure Requirements

Output Signal Range Throttling (On/Off)	Normal Operating Supply Pressure ⁽¹⁾	Maximum Allowable Supply Pressure to Prevent Internal Part Damage	Steady-State Air Consumption SCFH (Standard Cubic Feet Per Hour)	
			Proportional Band Set to 5	Proportional Band Set to 0 or 10
3 - 15 (0 - 20) Psig	20 Psig	40 Psig	minimum 10 maximum 34	minimum 2 maximum 30
21 - 103 (0 - 103) kPag	138 kPag	276 kPag		
6 - 30 (0 - 35) Psig	35 Psig	40 Psig	minimum 10 maximum 34	minimum 5 maximum 6
41 - 207 (0 - 241) kPag	241 kPag	276 kPag		

NOTE:

(1) Control may be degraded if this pressure is exceeded.

OPERATING PRINCIPLES

The Model 4000 Series pressure controller operation is based on the pressure-balanced relay with its bridged double diaphragm assembly. In the relay, the supply pressure bleeds through the fixed orifice before passing through the nozzle, to register on the large relay diaphragm, and controller output pressure on the small relay diaphragm.

With steady state process pressure, the Bourdon tube is held steady in relation to the nozzle, allowing pressure to be released between the nozzle and beam-flapper assembly at the same rate released through the fixed orifice.

A process pressure change either expands or contracts the arc of the Bourdon tube, thereby moving the beam-flapper assembly with respect to the nozzle.

An increasing process pressure with direct action produces a nozzle to flapper restriction that increases the pressure on the large relay diaphragm, causing the relay valve to close at the exhaust end and to open at the supply end. The additional supply pressure passes through the relay housing to increase the output signal (loading pressure to the final control device).

In the opposite case of a falling process pressure with direct action creates a larger nozzle flapper gap that releases pressure from the large relay diaphragm, causing the relay valve inlet to close, thereby opening the exhaust, and reducing the output signal (loading pressure to the control device).

Proportional-Only Controllers - Model 4000

The controller output signal is fed back to the proportional bellows, off setting the nozzle pressure change and balancing the pressure differential across the relay diaphragm. The relay valve establishes the new output signal (loading pressure to the final control device) based on the change in the controller set pressure.

When the proportional valve is at the maximum dial setting (wide open), all the controller output pressure change is fed back to the proportional bellows, for a proportional band of 100%. As the proportional valve is closed, more controller output pressure change passes back through the proportional valve exhaust, reducing the feed back to the proportional valve exhaust, and thereby reducing the proportional band.

See Figure 3 for Proportional-only controller adjustment locations.

Proportional-Plus-Reset Controllers - Model 4010

The 4010 Series controllers have a two-way reset restriction valve that controls (delays) the speed of the proportional pressure flow into the reset bellows (which oppose the proportional bellows action). The reset valve can be adjusted to vary the delay (reset) time.

See Figure 4 for Proportional-plus-reset controller adjustment locations.



Model 4000 Pressure Controller

Technical Sales Bulletin

OPERATING PRINCIPLES (Continued)

Differential-Gap Controller - Model 4030

On/off action is obtained by connecting the proportional bellows so that feedback pressure forces the beam and flapper in the same direction as caused by the sensed pressure.

A decreasing process pressure with direct action (reverse action - increasing pressure) produces a nozzle to flapper restriction that reduces pressure on the large relay diaphragm. The relay valve inlet will then close and the exhaust port will open, therefore removing the output signal from the final control device.

The summing of feedback bellows movement, and the beam-flapper assembly movement, drives the relay valve either to available supply pressure or to complete exhaust, with no throttling action.

PRESSURE DEFINITIONS

Deadband

The amount which the measured input can change without causing a change in output signal.

Repeatability

The ability of an instrument to reproduce an output signal when a set input signal is applied repeatedly.

Differential Gap

A form of on/off control where the difference between the switch points is adjustable.

Figure 2 Operational Schematic for Pressure Control Application

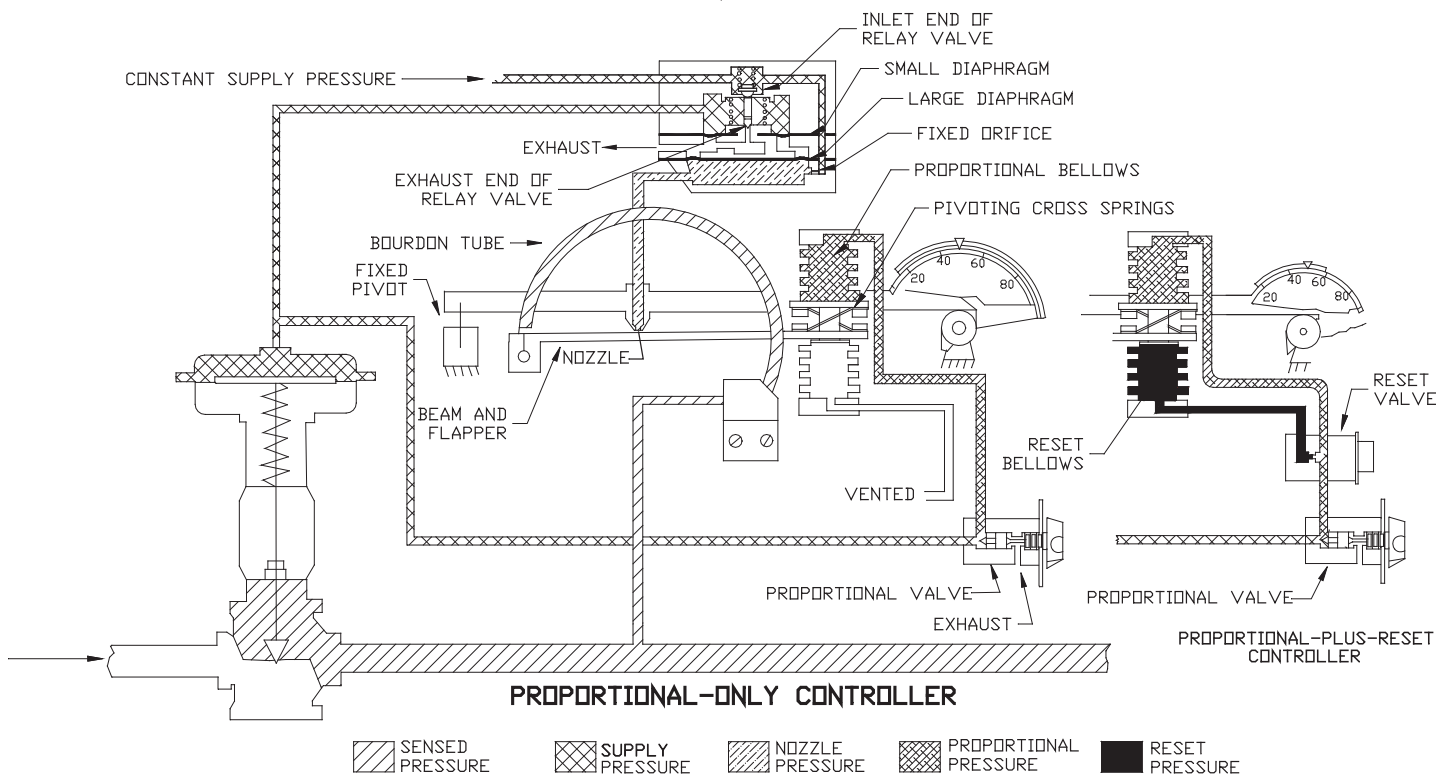

Direct-Acting Proportional-Only & Proportional-Plus-Reset Controllers

Model 4000 Pressure Controller

Technical Sales Bulletin



Figure 3 Proportional Only Controller

Figure 4 Proportional With Reset Controller

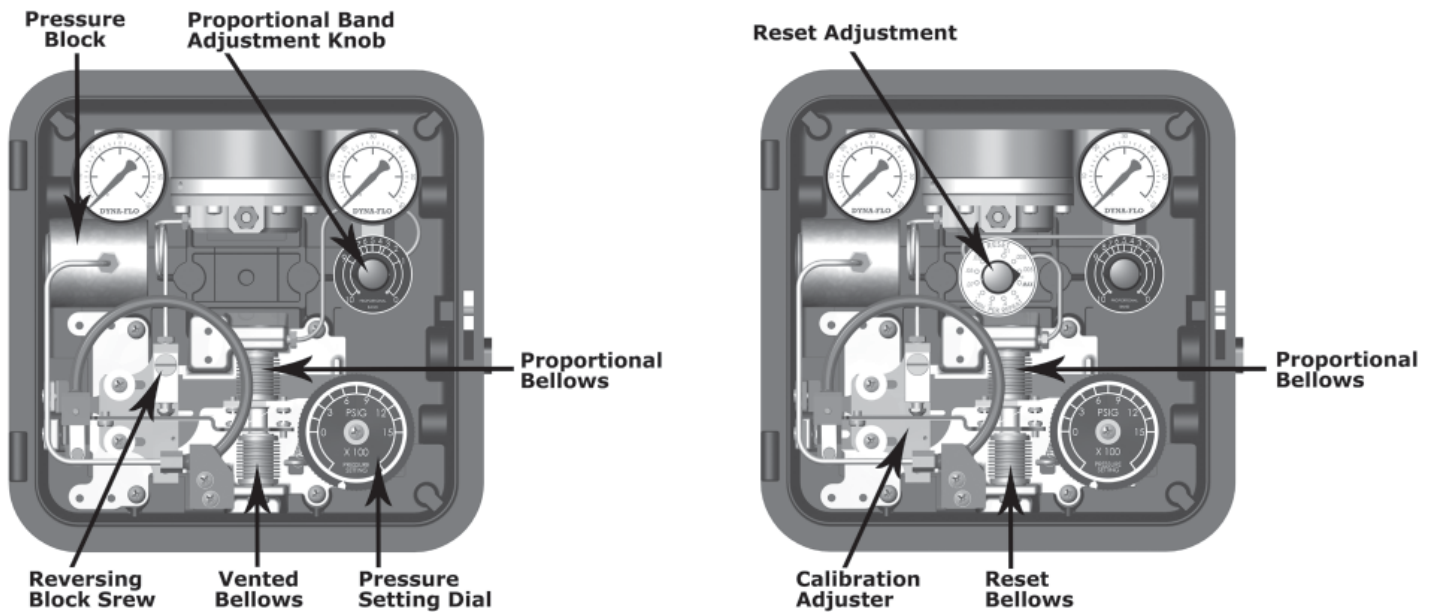

Table 3

Construction Materials

Contact	Part	Standard Material	Optional Material
With Process	Bourdon Tube	Stainless Steel	N05500
	Pressure Block	Forged Steel	Stainless Steel
	Control Tubing	Stainless Steel	-
With Operating Medium (at pressure)	All other interior tubing	Stainless Steel	-
	Nozzle and Reversing Block	Stainless Steel/Aluminum	Stainless Steel/Aluminum
	Relay Springs and Spring Plate	Steel	Steel
	Relay Diaphragms	Neoprene/Nylon	Neoprene/Nylon
	Other metal relay parts	Zinc/Aluminum/Stainless Steel	Zinc/Aluminum/Stainless Steel
	Proportional, Reset Bellows	Stainless Steel/Aluminum	Stainless Steel
	Proportional Valve Assembly	Aluminum/Stainless Steel	Aluminum/Stainless Steel
	O-rings	Nitrile	Nitrile
	Gaskets	Neoprene	Neoprene
Reset Valve Assembly	Aluminum/Stainless Steel	Aluminum/Stainless Steel	
With Operating Medium (at atmospheric pressure)	Case and Adjustment Dial	Powder Coated Aluminum	Powder Coated Aluminum
	Cover	Powder Coated	Powder Coated
	Flapper	Stainless Steel	Stainless Steel
	Control Link	Stainless Steel	Stainless Steel
	Flexure and Pressure Setting	Aluminum/Steel/Stainless	Aluminum/Steel/Stainless
	Adjustment Assemblies	Steel/Plastic	Steel/Plastic
	O-rings	Nitrile	Nitrile
	Calibration Adjuster and Proportional Adjustment Assembly	Aluminum	Aluminum



Model 4000 Pressure Controller

Technical Sales Bulletin

Figure 5 Dimensions, and Panel, Wall, and Pipestand Mounting

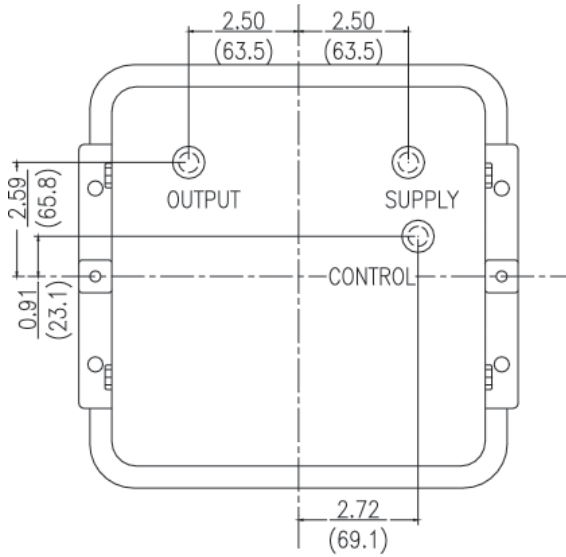

Back View

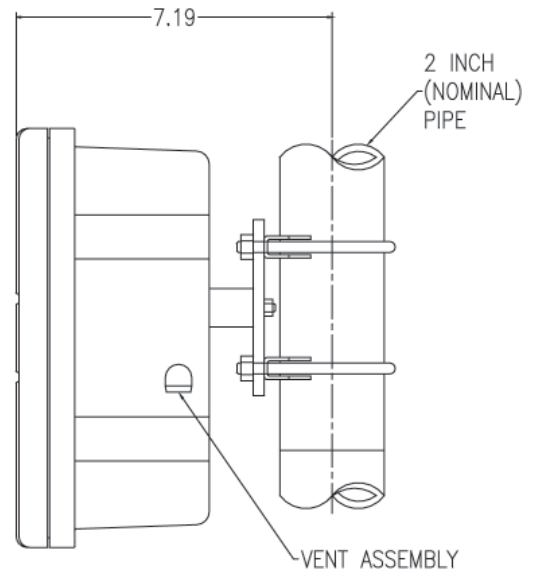

Pipestand Mounting

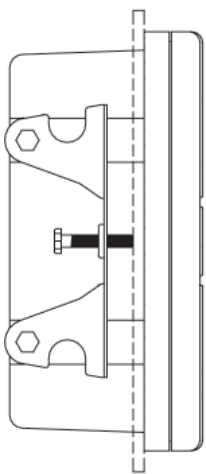

Panel Mounting

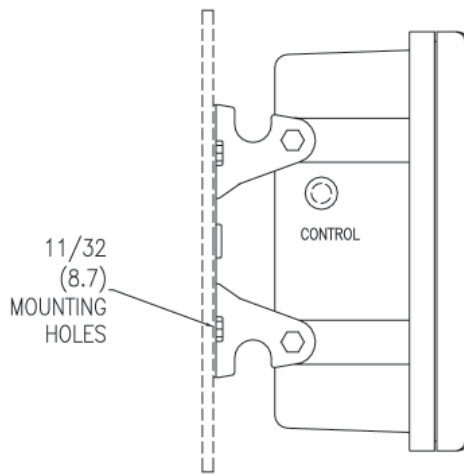

Wall Mounting

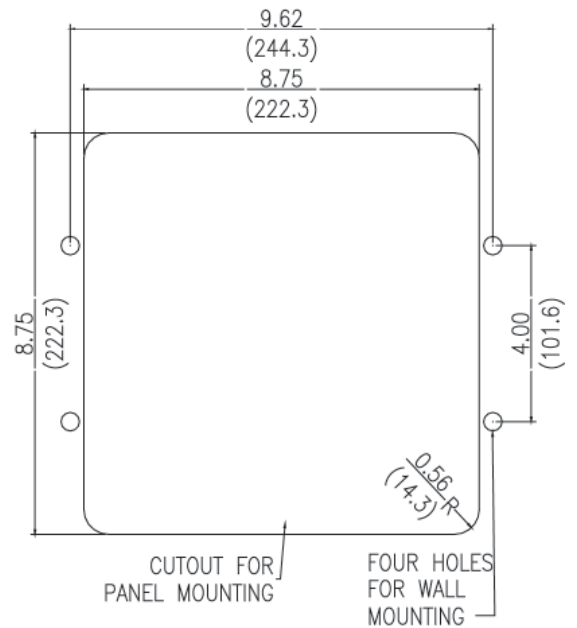

INCH
(mm)

Model 4000 Pressure Controller

Technical Sales Bulletin



Figure 10
Actuator Mounting

NOTE

When using yoke style or pipestand mounting, DON'T PUNCH HOLES in back of case. Use drill (5/16 bit).

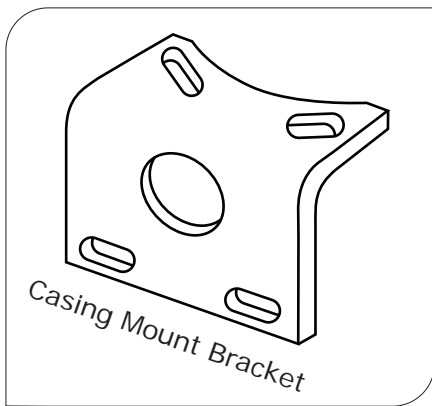
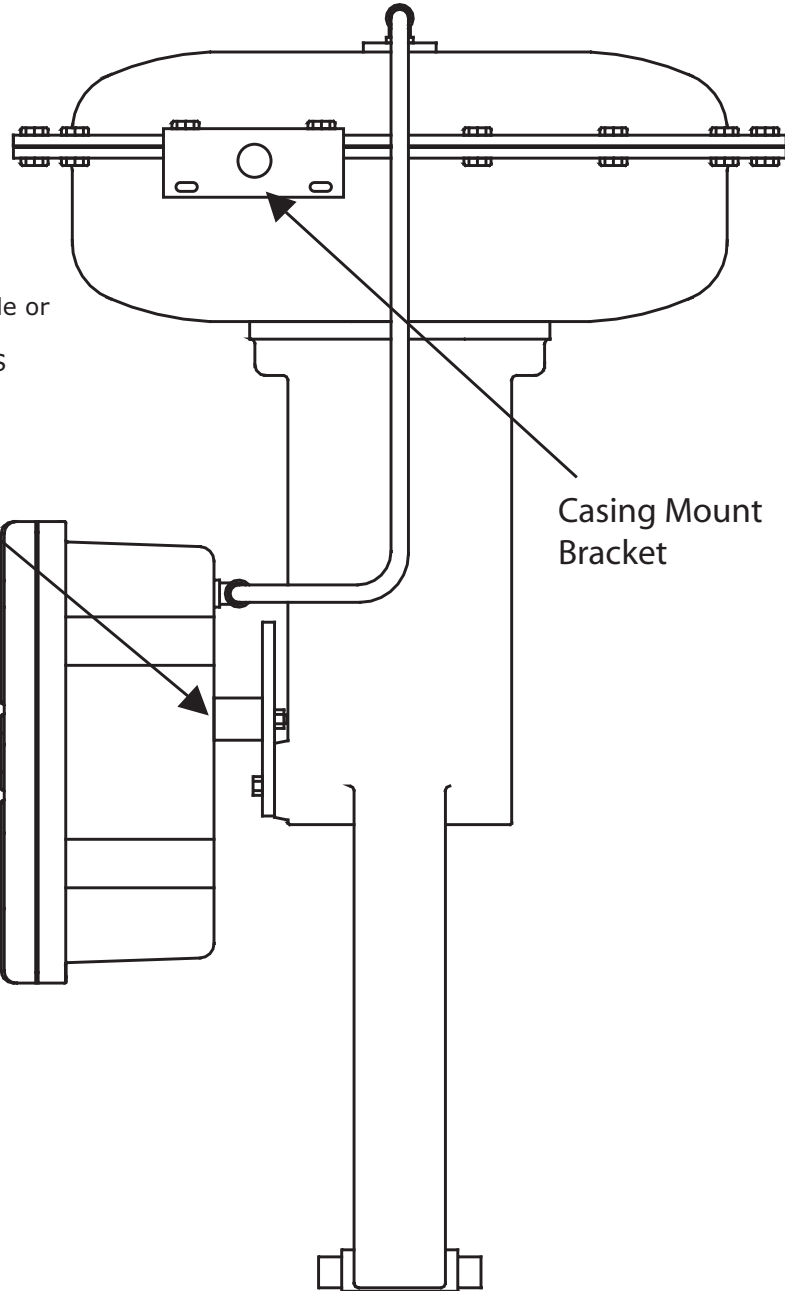



Model 4000 Pressure Controller

MODEL NUMBERING SYSTEM

SAMPLE PART NUMBER: 4000-010-D-10

CONTROLLER MODE				00
00	PROPORTIONAL	10	PROPORTIONAL + RESET	
30	DIFFERENTIAL GAP			
INPUT SIGNAL RANGE				010
003	0 to 30 PSIG (0 TO 207 KPAG)	006	0 to 60 PSIG (0 TO 414 KPAG)	
010	0 to 100 PSIG (0 TO 689 KPAG)	020	0 to 200 PSIG (0 TO 1,379 KPAG)	
030	0 to 300 PSIG (0 TO 2,068 KPAG)	060	0 to 600 PSIG (0 TO 4,137 KPAG)	
100	0 to 1,000 PSIG (0 TO 6,895 KPAG)	150	0 to 1,500 PSIG (0 TO 10,342 KPAG)	
300	0 to 3,000 PSIG (0 TO 20,684 KPAG)	500	0 to 5,000 PSIG (0 TO 34,474 KPAG)	
NOTE: CONSULT DYNA-FLO FOR HIGHER INPUT SIGNAL RANGES.				
CONTROLLER ACTION				D
D	DIRECT	R	REVERSE	
OPTIONS				-
-	NONE (STANDARD)	S	BOURDON TUBE STOP	
CONTROLLER OUTPUT				1
1	3 TO 15 PSIG (21 TO 103 KPAG) / 0 TO 20 PSIG (0 TO 138 KPAG)			
2	6 TO 30 PSIG (41 TO 207 KPAG) / 0 TO 30 PSIG (0 TO 207 KPAG)			
OPTIONS				0
0	NONE	1	NACE PROCESS ONLY	
2	SOUR INSTRUMENT ONLY	3	NACE PROCESS AND SOUR INSTRUMENT	
NOTE: ORDER MOUNTING KITS SEPARATELY.				

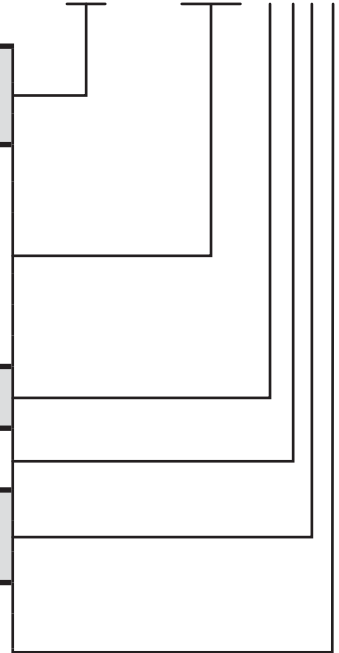

40 - - - - -

Our Commitment to Quality

Dyna-Flo is committed to continuous improvement. While all efforts have been made to ensure the accuracy of the content in this document, modifications or improvements to the information, specifications, and designs may occur at any time without notice. This document was published for informational purposes only, and does not express or imply suitability, a warranty, or guarantee regarding the products or services described herein or their use or applicability.

Neither Dyna-Flo Control Valve Services Ltd., nor any of their affiliated entities assumes responsibility for the selection, use and maintenance of any product. Responsibility for selection, use and maintenance of any product remains with the purchaser and end-user.